

# Innovative Ag Products

## Speedy Pit

### Key Features:

- 10' x 24' Grated Area
- 1,100 Bushel Capacity
- 7 Gage Construction
- Painted 2-part Epoxy (Bed liner)
- Rack & Pinion Controlled Roller Gate
- Inside Access Ladder
- Switch Mounting Plate Inside Pit

### Options Available

- Custom Sizes Available
- Custom Auger up to 18"
- 12'x26' Pit Cover
- In House Site Layout
- Custom Pit Enclosure
- Dewatering system
- Reclaim hopper

Our in-ground receiving pit is ideal for everyone! Do you want to speed up your unloading process and return to the field faster than ever before? Our Speedy Pit was designed with the farmer in mind. The first thing we hear as the manufacturer, after one of our Speedy Pits has

been installed, is that our customer was not only able to save time but money as well by eliminating a truck and a driver from the hauling process. Holding capacity of the Speedy Pit is 1,100 bushels. Unloading trucks takes only minutes with the capability to dump both hoppers simultaneously. Our Speedy Pit was designed in a 3 piece modular system to allow for fast and economical installation. This allows the unit to be shipped on a standard flatbed semi trailer in one load without the need for special permits, decreasing freight cost. The Speedy Pit is made with a standard 20" tube, that enables any size auger up to 18" in diameter. At the base of the pit we have a roller gate controlled by a rack and pinion design. The control wheel, located at the top of the tube, allows you to adjust and shut off flow to the auger.

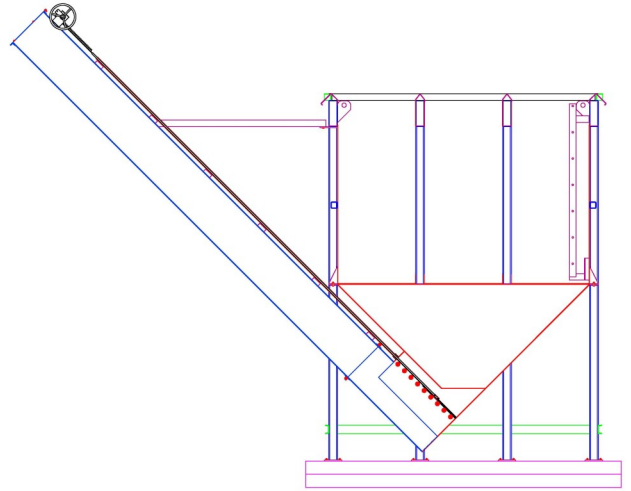

## Contact Us For Pricing!

Innovative Ag Products  
4326 Highway 212  
Montevideo, MN 56265  
[www.innovativeagproducts.com](http://www.innovativeagproducts.com)  
[info@innovativeagproducts.com](mailto:info@innovativeagproducts.com)  
320-321-0836

